

Compression Fittings
HDPE / LDPE
&
PPR-C Pipes

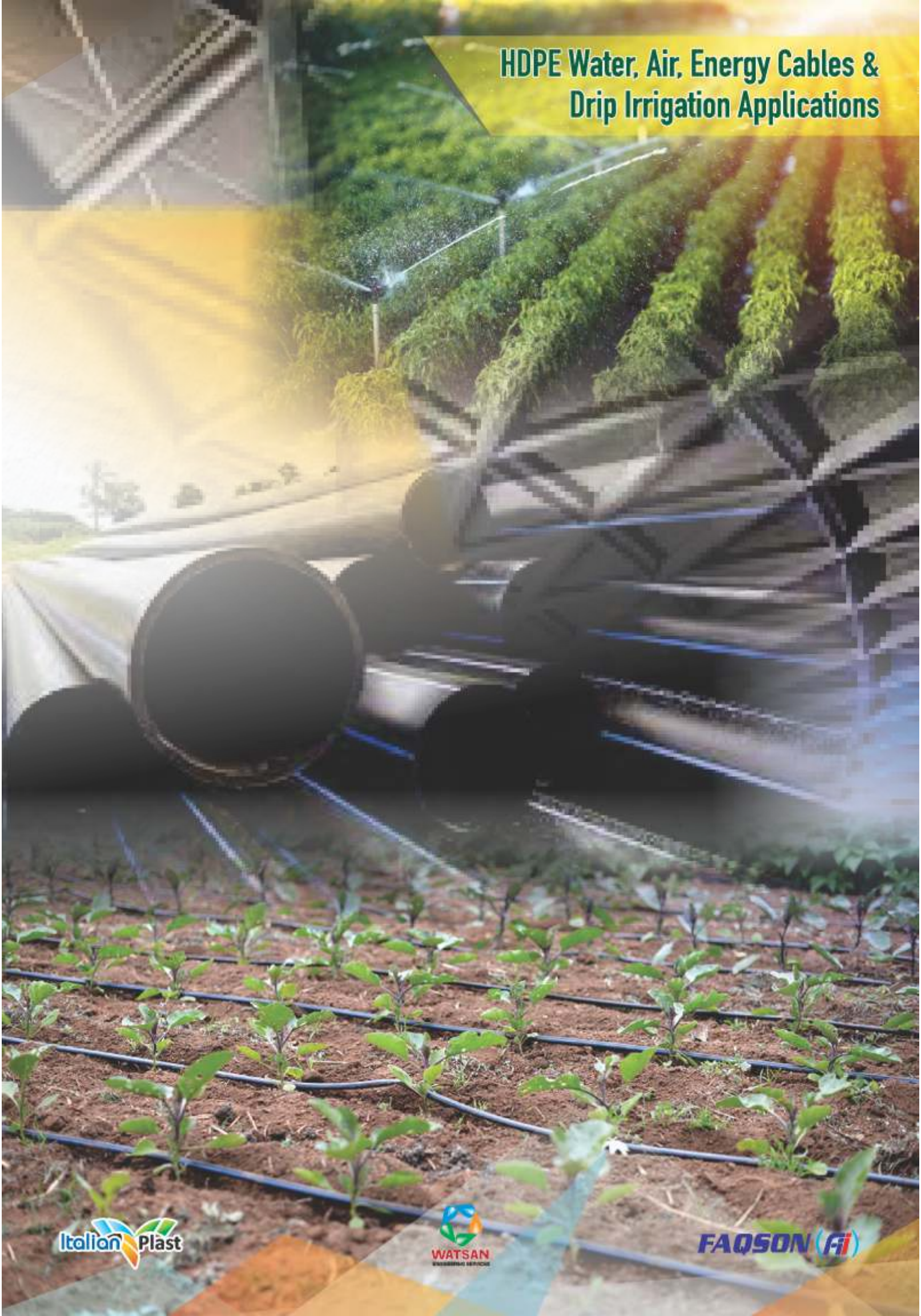

HDPE Water, Air, Energy Cables & Drip Irrigation Applications



FAQSON INTERNATIONAL INDUSTRIES INTRODUCTION:

FAQSON INTERNATIONAL INDUSTRIES, established in 2018 as manufacturing company, with association of WATSAN ENGINEERING SERVICES having involved in trading and industrial business of Pipe and fittings in Pakistan market since 2010 and both companies having head office based in Rawalpindi, Pakistan. We are manufacturer and distributor of HDPE, LDPE, TELECOM & ELECTRIC Duct, UPVC and PPRC Pipes and Fittings for Water, Gas, Irrigation, and Telecommunication ducts and Electric conduits for infrastructure, Long haul, Building MEP products for domestic and international market.

As part of fittings business, we have state of the art injection molding machines and fully automatic injection molds for manufacturing of PP Compression Fittings in ranges from 16mm to 110mm along with clamp saddles up to 25mm to 250mm

INTRODUCTION COMPRESSION FITTINGS:

Compression Fittings for pressure piping applications are characterized by the Innovative Balance Sealing System, Thanks to the new technical design it is possible to balance the sealing action towards the pipe through the different tightening of the nut. This leads to the maximum safety in all the possible conditions of use and quality of the pipe, keeping the basic features of easy and fast assembly without any particular preparation of the pipe. Product range: d.16-110mm, all the common items for piping applications.

Product Range: DN-16 - DN110mm.

MAIN APPLICATIONS:

MAIN APPLICATIONS Water supply, house connection and water treatment plants, Air and Gas, sport plants irrigation and gardening, agriculture and horticulture irrigation.

TECHNICAL SPECIFICATIONS:

Materials: - Top quality raw materials are used, this makes the fittings highly resistant and reliable in time, suitable for drinking water and environment compatibility for Air, Gas, Irrigation and Cable Ducting Applications as specified and required.

Material Properties of Assembled Compression Fittings:

| Mechanical / Physical Properties of Material | Test Method Standard | Unit | Value |
|--|----------------------|--------------------|-------|
| Specific Gravity (Co PP Block) | ASTM D792 | g/cm ³ | 0.9 |
| Specific Gravity (Acetal) | ISO 1183 | g/cm ³ | 1.41 |
| Melt Index (190°C, 2.16kg) (Co PP Block) | D1238 | g/10min | 0.30 |
| Melt Index (190°C, 2.16kg) (Acetal) | ISO 1133 | g/10min | 27.0 |
| Tensile Strength (Co PP Block) | D638 | Kg/cm ² | 320 |
| Tensile Strength (Acetal) | ISO527-1/2 | Mpa | 65 |
| Rockwell Hardness (Co PP Block) | D785 | M Scale | 95 |
| Rockwell Hardness (Acetal) | ISO 2039-2 | M Scale | 95 |
| Country of Origin: | Pakistan | | |

| GENERAL DETAILS NBR - BLACK RUBBER | | | |
|--|------------|-------------------|-------|
| DMR NBR is a black Nitrile Butadiene Rubber, commonly referred to as NBR, Nitrile or Buna. Good physical properties and chemical resistance to the most common hydraulic fluids makes NBR an excellent sealing material. NBR materials are one of the most commonly used elastomers in sealing applications. | | | |
| PHYSICAL PROPERTIES | STANDARD | UNIT | VALUE |
| Specific Gravity | DIN 53479 | g/cm ³ | 1.32 |
| Hardness at 20°C | DIN 53505 | Shore A | 70 |
| Tensile Strength | DIN 53504 | N/mm ² | >17 |
| Elongation at break | DIN 53504 | % | >155 |
| Modulus 100% | DIN 53504 | N/mm ² | 10.2 |
| Compression set 22h / 70°C | DIN 53517A | % | 7 |
| Compression set 22h / 100°C | DIN 53485 | % | 9 |
| Min Service Temperature | | °C | -25 |
| Max Service Temperature | | °C | 100 |
| Country of Origin: | Pakistan | | |

| PP COMPRESSION FITTINGS STANDARD AND COMPLIANCE | |
|---|---|
| Ref. Standard | ISO 17885 / DIN 8076 |
| Complying Standard | ISO 4427, DIN 8074/8075, PS 3580: 1994 |
| Type of Joint: | Compression Type |
| Body: | Polypropylene Copolymer (PP-B) - Black |
| Lock Nut: | Polypropylene Copolymer (PP-B) - Blue |
| Spacer Ring: | Polypropylene Copolymer (PP-B) - Black |
| Grip Ring: | Polycetal (POM) - White |
| O-Ring: | Black Nitrile Rubber NBR, Shore Hardness 70 |
| Pressure Rating: | Standard 20mm - 110mm PN16 & PN10 |
| Brand: | ITALIAN PLAST CLASSIC BLUE SERIES (Made in UAE) |
| Country of Origin: | Pakistan |

STANDARDS:

Dimensions, features and functional tests: ISO4427, DIN-8074, DIN-8075, DIN-8076.3, PS-3580:1994, ISO-3501, ISO-3503, ISO-3459 & ISO-3548. UNI 9561, EN712 - EN713 - EN715 & EN911, Pipe compatibility, PE-HD (PE63-80-100), PE-LD, PEX-a and PPR-C Pipes: Sealing threads (male and female): EN10226-1 (ex ISO7/1), DIN2999.1, BS21, AS/NZS1722.1 and Flange: ISO7005, DIN2501 - DIN8063.

WORKING TEMPERATURE (°C):

Minimum (-) 10 °C & Maximum (+) 50 °C, For Gas & Air Maximum 30°C

Working Pressure and Temperature:

| Temperature°C | -10 /+25°C | +26/+35°C | +36/+50°C |
|---------------|------------|-----------|-----------|
| PN | 16 | 12,5 | 10 |
| PN | 12,5 | 10 | 8 |
| PN | 10 | 8 | 6 |

Note: For Gas & Air Maximum Pressure Upto 6 Bars at 30 °C Temperature.

COMPRESSION FITTINGS ASSEMBLY INSTRUCTIONS

1. PIPE PREPARATION & CAP UNSCREW:

Cut the pipe round and square and remove the burrs; better to chamfer greater than 75mm. Unscrew the Cap to the last thread, leave it on the fitting while inserting the pipe.



2. PIPE INSERTION UP TO THE FIRST PIPE STOP:

Twist the pipe into the fitting through the grip ring till the first stop: the pipe has reached the O Ring. Pipe insertion up to the first pipe stop Balance sealing system The O Ring has two opposite lips that allows easier pipe insertion. The right placing of the O Ring in the body round to avoid twisting. The better adaptability of the O Ring towards the body and the pipe wall (large contact pipe surface)

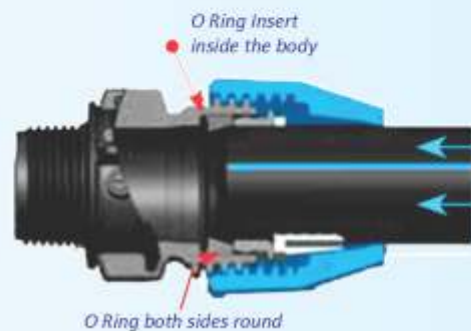

3. PIPE INSERTION UP TO THE BODY PIPE STOP:

Push the pipe through the gasket till the second stop, you have reached the pipe stop ribs of the fitting.

Balancing of O Ring

The radial body site and the conical gasket are designed to keep the gasket lightly up in the site: after the pipe insertion it doesn't reach directly the body pipe stop, it also remains a little raised from the pipe stop thanks to the internal ribs in the body.



4. SCREWING THE CAP:

Tighten the Cap firmly by hand or standard tool up to 20-32mm, and by standard Pipe wrench for greater than 40mm; the pipe moves to the very final body stop

Balancing of O Ring:

By tightening the Cap it works on the thrust ring that push the O Ring, meanwhile the pipe is moving to the final stop in the body; the O Ring can deeply place in its site also moving radially and increasing its compression towards the pipe wall, as much as it's possible in relation to the dimensional. In this way, acting on the tightening level of the Cap, it is possible to realize a system able to balance pipe defects such as undersize and ovality in standard

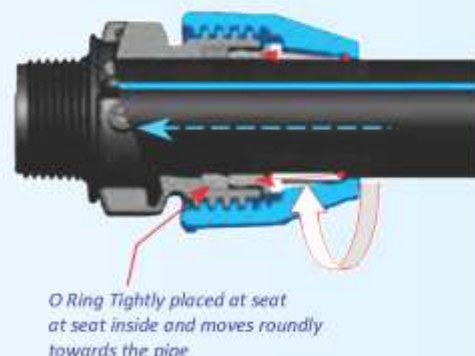

PP Straight Coupler

مقرنة مستقيمة
Прямая муфта
Coupleur droit
Acoplador recto



| | |
|-------|-------|
| SC001 | 20mm |
| SC002 | 25mm |
| SC003 | 32mm |
| SC004 | 40mm |
| SC005 | 50mm |
| SC006 | 57mm |
| SC007 | 63mm |
| SC008 | 75mm |
| SC009 | 90mm |
| SC010 | 110mm |
| | |
| | |

PP Equal Elbow

كوع متساوي
Равный локоть
Coude égal
Codo igual



| | |
|-------|-------|
| EE001 | 20mm |
| EE002 | 25mm |
| EE003 | 32mm |
| EE004 | 40mm |
| EE005 | 50mm |
| EE006 | 63mm |
| EE007 | 75mm |
| EE008 | 90mm |
| EE009 | 110mm |
| | |
| | |

PP Equal Tee

بساوي نقطة الإطلاق
Равная футболка
T-shirt égal
Camiseta igual



| | |
|-------|-------|
| ET001 | 20mm |
| ET002 | 25mm |
| ET003 | 32mm |
| ET004 | 40mm |
| ET005 | 50mm |
| ET006 | 63mm |
| ET007 | 75mm |
| ET008 | 90mm |
| ET009 | 110mm |
| | |
| | |

PP Equal Valve

صمام متساوي
Равный клапан
Valve égale
Válvula igual



| | |
|-------|---------------|
| EV001 | 20mm x 20mm |
| EV002 | 25mm x 25mm |
| EV003 | 32mm x 32mm |
| EV004 | 40mm x 40mm |
| EV005 | 50mm x 50mm |
| EV006 | 63mm x 63mm |
| EV007 | 75mm x 75mm |
| EV008 | 90mm x 90mm |
| EV009 | 110mm x 110mm |
| | |
| | |

PP Flange Adaptor

محول شفة

Фланцевый адаптер
Adaptateur de bride
Adaptador de brida



| | |
|--------|---------------|
| FLA001 | 40mm x 1-1/2" |
| FLA002 | 50mm x 1-1/2" |
| FLA003 | 50mm x 2" |
| FLA004 | 63mm x 2" |
| FLA005 | 63mm x 2-1/2" |
| FLA006 | 75mm x 2-1/2" |
| FLA007 | 75mm x 3" |
| FLA008 | 90mm x 3" |
| FLA009 | 90mm x 4" |
| FLA010 | 110mm x 4" |

PP End Cap

تهاية كاب

Торцевая крышка
Embout
Tapa final



| | |
|-------|-------|
| EC001 | 20mm |
| EC002 | 25mm |
| EC003 | 32mm |
| EC004 | 40mm |
| EC005 | 50mm |
| EC006 | 63mm |
| EC007 | 75mm |
| EC008 | 90mm |
| EC009 | 110mm |

PP Reducing Tee

تخفيض نقطة الإنطلاق

Уменьшающий тройник
T-shirt de réduction
Reducir Tee



| | |
|-------|--------------|
| RT001 | 25mm x 20mm |
| RT002 | 32mm x 20mm |
| RT003 | 32mm x 25mm |
| RT004 | 40mm x 20mm |
| RT005 | 40mm x 25mm |
| RT006 | 40mm x 32mm |
| RT007 | 50mm x 25mm |
| RT008 | 50mm x 32mm |
| RT009 | 50mm x 40mm |
| RT010 | 63mm x 25mm |
| RT011 | 63mm x 32mm |
| RT012 | 63mm x 40mm |
| RT013 | 63mm x 50mm |
| RT014 | 75mm x 50mm |
| RT015 | 75mm x 63mm |
| RT016 | 90mm x 50mm |
| RT017 | 90mm x 63mm |
| RT018 | 90mm x 75mm |
| RT019 | 110mm x 63mm |
| RT020 | 110mm x 75mm |
| RT021 | 110mm x 90mm |

PP Reducing Coupler

تخفيض مقربة

Переходная муфта
Réducteur de coupleur
Acoplador reductor



| | |
|-------|--------------|
| RC001 | 25mm x 20mm |
| RC002 | 32mm x 20mm |
| RC003 | 32mm x 25mm |
| RC004 | 40mm x 20mm |
| RC005 | 40mm x 25mm |
| RC006 | 40mm x 32mm |
| RC007 | 50mm x 25mm |
| RC008 | 50mm x 32mm |
| RC009 | 50mm x 40mm |
| RC010 | 63mm x 25mm |
| RC011 | 63mm x 32mm |
| RC012 | 63mm x 40mm |
| RC013 | 63mm x 50mm |
| RC014 | 75mm x 50mm |
| RC015 | 75mm x 63mm |
| RC016 | 90mm x 50mm |
| RC017 | 90mm x 63mm |
| RC018 | 90mm x 75mm |
| RC019 | 110mm x 63mm |
| RC020 | 110mm x 75mm |
| RC021 | 110mm x 90mm |

PP Male Elbow

ذكر الكوع
Мужской локоть
Coude masculin
Codo macho



| | |
|-------|----------------|
| ML001 | 20mm x 1/2" |
| ML002 | 20mm x 3/4" |
| ML003 | 25mm x 1/2" |
| ML004 | 25mm x 3/4" |
| ML005 | 25mm x 1" |
| ML006 | 25mm x 1-1/4" |
| ML007 | 25mm x 1-1/2" |
| ML008 | 32mm x 3/4" |
| ML009 | 32mm x 1" |
| ML010 | 32mm x 1-1/4" |
| ML011 | 32mm x 1-1/2" |
| ML012 | 40mm x 1" |
| ML013 | 40mm x 1-1/4" |
| ML014 | 40mm x 1-1/2" |
| ML015 | 50mm x 1-1/4" |
| ML016 | 50mm x 1-1/2" |
| ML017 | 50mm x 2" |
| ML018 | 63mm x 1-1/2" |
| ML019 | 63mm x 2" |
| ML020 | 63mm x 2-1/2" |
| ML021 | 75mm x 2" |
| ML022 | 75mm x 2-1/2" |
| ML023 | 75mm x 3" |
| ML024 | 90mm x 2-1/2" |
| ML025 | 90mm x 3" |
| ML026 | 110mm x 2-1/2" |
| ML027 | 110mm x 3" |
| ML028 | 110mm x 4" |

PP Female Elbow

كوع أنثى
Женский локоть
Coude femelle
Codo femenino



| | |
|-------|----------------|
| FL001 | 20mm x 1/2" |
| FL002 | 20mm x 3/4" |
| FL003 | 25mm x 1/2" |
| FL004 | 25mm x 3/4" |
| FL005 | 25mm x 1" |
| FL006 | 25mm x 1-1/4" |
| FL007 | 32mm x 1/2" |
| FL008 | 32mm x 3/4" |
| FL009 | 32mm x 1" |
| FL010 | 32mm x 1-1/4" |
| FL011 | 32mm x 1-1/2" |
| FL012 | 40mm x 1" |
| FL013 | 40mm x 1-1/4" |
| FL014 | 40mm x 1-1/2" |
| FL015 | 50mm x 1-1/4" |
| FL016 | 50mm x 1-1/2" |
| FL017 | 50mm x 2" |
| FL018 | 63mm x 1-1/2" |
| FL019 | 63mm x 2" |
| FL020 | 63mm x 2-1/2" |
| FL021 | 75mm x 2" |
| FL022 | 75mm x 2-1/2" |
| FL023 | 75mm x 3" |
| FL024 | 90mm x 2-1/2" |
| FL025 | 90mm x 3" |
| FL026 | 110mm x 2-1/2" |
| FL027 | 110mm x 3" |
| FL028 | 110mm x 4" |

PP Male Adaptor

محول ذكر

Мужской адаптер
Adaptateur mâle
Adaptador macho



| | |
|-------|----------------|
| MA001 | 20mm x 1/2" |
| MA002 | 20mm x 3/4" |
| MA003 | 25mm x 1/2" |
| MA004 | 25mm x 3/4" |
| MA005 | 25mm x 1" |
| MA006 | 25mm x 1-1/4" |
| MA007 | 25mm x 1-1/2" |
| MA008 | 32mm x 3/4" |
| MA009 | 32mm x 1" |
| MA010 | 32mm x 1-1/4" |
| MA011 | 32mm x 1-1/2" |
| MA012 | 40mm x 1" |
| MA013 | 40mm x 1-1/4" |
| MA014 | 40mm x 1-1/2" |
| MA015 | 50mm x 1-1/4" |
| MA016 | 50mm x 1-1/2" |
| MA017 | 50mm x 2" |
| MA018 | 63mm x 1-1/2" |
| MA019 | 63mm x 2" |
| MA020 | 63mm x 2-1/2" |
| MA021 | 63mm x 3" |
| MA022 | 75mm x 2" |
| MA023 | 75mm x 2-1/2" |
| MA024 | 75mm x 3" |
| MA025 | 90mm x 2-1/2" |
| MA026 | 90mm x 3" |
| MA027 | 90mm x 4" |
| MA028 | 110mm x 2" |
| MA029 | 110mm x 2-1/2" |
| MA030 | 110mm x 3" |
| MA031 | 110mm x 4" |

PP Female Adaptor

محول انثى

Женский адаптер
Adaptateur femelle
Adaptador hembra



| | |
|-------|----------------|
| FA001 | 20mm x 1/2" |
| FA002 | 20mm x 3/4" |
| FA003 | 25mm x 1/2" |
| FA004 | 25mm x 3/4" |
| FA005 | 25mm x 1" |
| FA006 | 25mm x 1-1/4" |
| FA007 | 25mm x 1-1/2" |
| FA008 | 32mm x 3/4" |
| FA009 | 32mm x 1" |
| FA010 | 32mm x 1-1/4" |
| FA011 | 32mm x 1-1/2" |
| FA012 | 32mm x 1-3/4" |
| FA013 | 40mm x 1" |
| FA014 | 40mm x 1-1/4" |
| FA015 | 40mm x 1-1/2" |
| FA016 | 50mm x 1-1/4" |
| FA017 | 50mm x 1-1/2" |
| FA018 | 50mm x 2" |
| FA019 | 63mm x 1-1/2" |
| FA020 | 63mm x 2" |
| FA021 | 63mm x 2-1/2" |
| FA022 | 75mm x 2" |
| FA023 | 75mm x 2-1/2" |
| FA024 | 75mm x 3" |
| FA025 | 90mm x 2-1/2" |
| FA026 | 90mm x 3" |
| FA027 | 90mm x 4" |
| FA028 | 110mm x 2" |
| FA029 | 110mm x 2-1/2" |
| FA030 | 110 mm x 3" |
| FA031 | 110mm x 4" |

PP Clamp Saddle

سرج المشبك
Седло зажима
Selle de serrage
Sillín de abrazadera

PP Clamp Saddle Specifications:

| Product Name | PP Clamp Saddles |
|-----------------|--|
| Available Sizes | DN 25mm - 250mm (DN - Nominal Diameter HDPE Pipe) |
| Pressure Rating | 25mm to 160mm PN16 & 180 to 315mm PN6 (PN-Nominal Pressure in Bars) |
| Material | Clamp Saddle material in Co PP Block, Bolts & Nuts Hot Dipped zinc galvanized steel, o-ring/gasket in NBR, |
| Color | Black/Grey (Or any OEM Specified Color) |
| Standard | EN 712/713/715/911; ISO 3501/3503/3458/3459. |
| Marking | Manufacturer (FAQSON) Standard Marking |

| | |
|-------|---------------|
| CS001 | 25mm x 1/2" |
| CS002 | 25mm x 3/4" |
| CS003 | 32mm x 1/2" |
| CS004 | 32mm x 3/4" |
| CS005 | 32mm x 1" |
| CS006 | 40mm x 1/2" |
| CS007 | 40mm x 3/4" |
| CS008 | 40mm x 1" |
| CS009 | 50mm x 1/2" |
| CS010 | 50mm x 3/4" |
| CS011 | 50mm x 1" |
| CS012 | 50mm x 1-1/4" |
| CS013 | 63mm x 1/2" |
| CS014 | 63mm x 3/4" |
| CS015 | 63mm x 1" |
| CS016 | 63mm x 1-1/4" |
| CS017 | 63mm x 1-1/2" |
| CS018 | 63mm x 2" |
| CS019 | 75mm x 1/2" |
| CS020 | 75mm x 3/4" |
| CS021 | 75mm x 1" |
| CS022 | 75mm x 1-1/4" |
| CS023 | 75mm x 1-1/2" |
| CS024 | 75mm x 2" |
| CS025 | 90mm x 1/2" |
| CS026 | 90mm x 3/4" |
| CS027 | 90mm x 1" |



| | |
|-------|----------------|
| CS028 | 90mm x 1-1/4" |
| CS029 | 90mm x 1-1/2" |
| CS030 | 90mm x 2" |
| CS031 | 110mm x 1/2" |
| CS032 | 110mm x 3/4" |
| CS033 | 110mm x 1" |
| CS034 | 110mm x 1-1/4" |
| CS035 | 110mm x 1-1/2" |
| CS036 | 110mm x 2" |
| CS037 | 125mm x 1/2" |
| CS038 | 125mm x 3/4" |
| CS039 | 125mm x 1" |
| CS040 | 125mm x 1-1/4" |
| CS041 | 125mm x 1-1/2" |
| CS042 | 125mm x 2" |
| CS043 | 160mm x 1/2" |
| CS044 | 160mm x 3/4" |
| CS045 | 160mm x 1" |
| CS046 | 160mm x 1-1/4" |
| CS047 | 160mm x 1-1/2" |
| CS048 | 160mm x 2" |
| CS049 | 160mm x 3" |
| CS050 | 180mm x 1/2" |
| CS051 | 180mm x 3/4" |
| CS052 | 180mm x 1" |
| CS053 | 180mm x 1-1/4" |
| CS054 | 180mm x 1-1/2" |



| | |
|-------|----------------|
| CS055 | 180mm x 2" |
| CS056 | 180mm x 3" |
| CS057 | 200mm x 1/2" |
| CS058 | 200mm x 3/4" |
| CS059 | 200mm x 1" |
| CS060 | 200mm x 1-1/4" |
| CS061 | 200mm x 1-1/2" |
| CS062 | 200mm x 2" |
| CS063 | 200mm x 3" |
| CS064 | 225mm x 1/2" |
| CS065 | 225mm x 3/4" |
| CS066 | 225mm x 1" |
| CS067 | 225mm x 1-1/4" |
| CS068 | 225mm x 1-1/2" |
| CS069 | 225mm x 2" |
| CS070 | 225mm x 3" |
| CS071 | 225mm x 4" |
| CS072 | 250mm x 1/2" |
| CS073 | 250mm x 3/4" |
| CS074 | 250mm x 1" |
| CS075 | 250mm x 1-1/4" |
| CS076 | 250mm x 1-1/2" |
| CS077 | 250mm x 2" |
| CS078 | 250mm x 3" |
| CS079 | 250mm x 4" |
| CS080 | 315mm x 1" |
| CS081 | 315mm x 2" |

PP Male Female Threaded Bush

ذكر أنثى الخيوط بوش
Втулка с наружной резьбой и внутренней резьбой
Bush fileté mâle femelle
Casquillo roscado macho hembra



| | |
|--------|-----------------|
| MFT001 | 3/4" x 1/2" |
| MFT002 | 1" x 3/4" |
| MFT003 | 1-1/8" x 1" |
| MFT004 | 1-1/2" x 3/4" |
| MFT005 | 1" x 1/2" |
| MFT006 | 1-1/8" x 1" |
| MFT007 | 1-1/2" x 1-1/8" |
| MFT008 | 2" x 1-1/4" |
| MFT009 | 2" x 1-1/2" |
| MFT010 | 2-1/2" x 1 1/4" |
| MFT011 | 2-3/4" x 1 1/2" |
| MFT012 | 2-3/4" x 2" |
| MFT013 | 3" x 1-1/2" |
| MFT014 | 3" x 2" |
| MFT015 | 3" x 2-1/2" |
| MFT016 | 4" x 2" |
| MFT017 | 4" x 2-1/2" |
| MFT018 | 4" x 3" |

PP Threaded Plug

للتوصيل الخيوط
Резьбовая пробка
Bouchon fileté
Tapón roscado



| | |
|-------|--------|
| TP001 | 1/2" |
| TP002 | 3/4" |
| TP003 | 1" |
| TP004 | 1-1/8" |
| TP005 | 1-1/2" |
| TP006 | 2" |
| TP007 | 2-1/2" |
| TP008 | 3" |
| TP009 | 4" |

PP Tapping Ferrule

PP tapping ferrule is the easiest way to tap water lines from mains. NO DRILLING NECESSARY. PP tapping ferrule incorporates its own cutter which can easily bore into PE pipes without the need for power tools. Additionally, PP tapping ferrule has a built-in stopper, which can serve to open or close the water line.

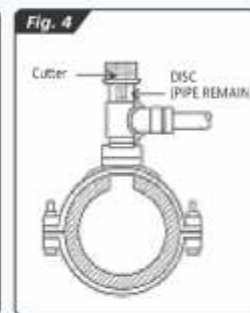
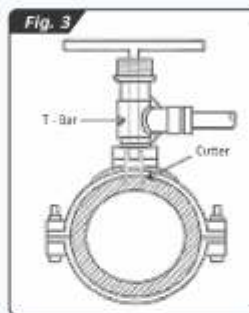
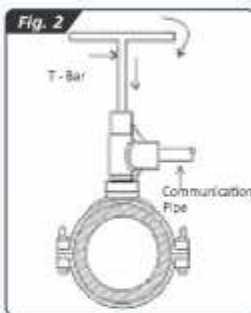
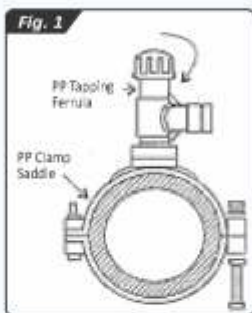

| | |
|----------------|---|
| PRODUCT | NEXOR Water Tap |
| APPLICATION | For tapping of service connection from water mains |
| TYPES | Injection molded and fabricated |
| INSTALLATION | Use of Open wrench and allen wrench |
| SIZES AVAILALE | 11/4" Main x 25 mm Tap 11/4" Main x 32 mm Tap (Fits to A Clamp Saddle with 11/4" Opening) |
| NOTES | Easy to install. Live tapping can be don (no need to turn off the water line) |



FAQSON ITALIAN PLAST HDPE WATER PIPE 90mm PN8 SDR21 ISO4427 KR123 10.18.04 00062 20/12/03

FAQSON ITALIAN PLAST HDPE WATER PIPE 90mm PN8 SDR21 ISO4427 KR123 10.21.33 00071 20/12/03

FAQSON ITALIAN PLAST HDPE WATER PIPE 90mm PN8 SDR21 ISO4427 KR123 10.08.04 00045 20/12/03

FAQSON ITALIAN PLAST HDPE WATER PIPE 90mm PN8 SDR21 ISO4427 KR123 10.04.03





COMPRESSION FITTINGS

HDPE / LDPE & PPR-C PIPES



Head Office/Factory:

Plot # 03, Street # W-3,
Rawat Industrial Estate (RIC)
Rawalpindi - Pinjab (Pakistan)
+92 51 8441421
+92 51 8441422

Rawalpindi Office:

Office # 16 & 18, Anwar Market,
Opp. Askari Bank, City Saddar Road,
Rawalpindi - Punjab (Pakistan)
+92-51-5554031, 5554025, 8441421
+92-51-8441422

Bhalwal Factory:

Plot # 2/19, Main Boulevard,
Bhalwal Industrial Estate
(BIE) Bhera Road, Bhalwal,
Distt. Sargodha - Punjab
(Pakistan)

Dubai Office:

Office # 2011,
Smart Heights,
Barsha South, Tecom,
Dubai, UAE.
+971555507073

info@watsanengg.com.pk

www.watsanengg.com.pk

info@faqsonint.net

www.faqsonint.net

